

DATASHEET: QLED EXTRA SLIM

SUPERIOR ELECTRONICS
LARGO LANCIANI, 24 - 00162 ROME

QLED EXTRA SLIM

CODE SUPSTV014

BARCODE 8054242081060

ITEM QLED Extra Slim

TV Lcd, Led, Plasma, Curved

WEIGHT CAPACITY 50kg / 110lbs

TILT RANGE +3° ~ -3°

MATERIAL Steel

OUTER CARTON 8 PCS

DISTANCE FROM THE WALL 17 - 92 mm

COMPATIBLE MODELS

- Q7C™ (49"/55"/65"), Q7CN™ (55"/65"), Q7F™ (49"/55"/65"), Q7FN™ (55"/65")
- Q8C™ (55"/65"), Q85R™ (55"/65")
- Q900™ (55"/65"), Q900R™ (55"/65"), Q950R™ (65"), Q950T™ (65"), Q95T™ (55"/65"), Q90R™ (55"/65"), Q9F™ (65"), Q9FN™ (55"/65")

ADDITIONAL CONTENT

- Cable management system
- Instructions manual
- 2 years warranty

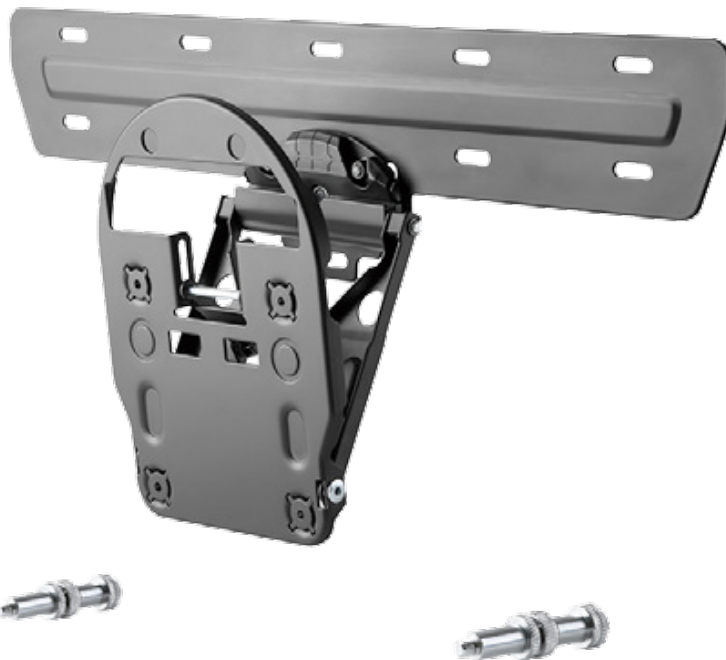

All mentioned product names, logos and brands are property of their respective owners