

SCHEDA TECNICA: QLED EXTRA SLIM

SUPERIOR ELECTRONICS
LARGO LANCIANI, 24 - 00162 ROMA

QLED EXTRA SLIM

CODICE	SUPSTV014
CODICE A BARRE	8054242081060
PRODOTTO	QLED Extra Slim
TV	Lcd, Led, Plasma, Curvi
CAPACITÀ DI CARICO	50kg / 110lbs
RAGGIO D'INCLINAZIONE	+3° ~ -3°
MATERIALE	Acciaio
CARTONE	8 PZ
DISTANZA DALLA PARETE	17 - 92 mm

MODELLI COMPATIBILI	<ul style="list-style-type: none">• Q7C™ (49"/55"/65"), Q7CN™ (55"/65"), Q7F™ (49"/55"/65"), Q7FN™ (55"/65")• Q8C™ (55"/65"), Q85R™ (55"/65")• Q900™ (55"/65"), Q900R™ (55"/65"), Q950R™ (65"), Q950T™ (65"), Q95T™ (55"/65"), Q90R™ (55"/65"), Q9F™ (65"), Q9FN™ (55"/65")
----------------------------	---

CONTENUTI AGGIUNTIVI	<ul style="list-style-type: none">• Sistemi di gestione dei cavi• Manuale d'istruzioni• 2 anni di garanzia
-----------------------------	--

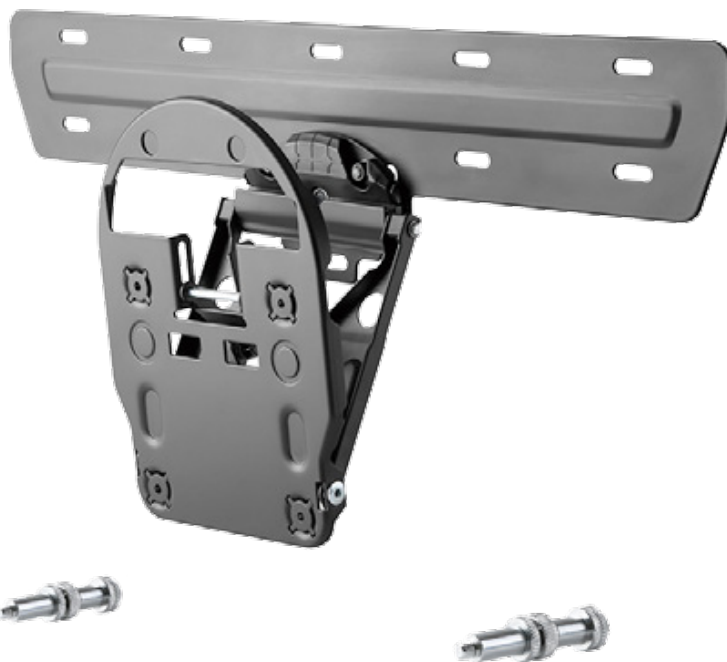

All mentioned product names, logos and brands are property of their respective owners